

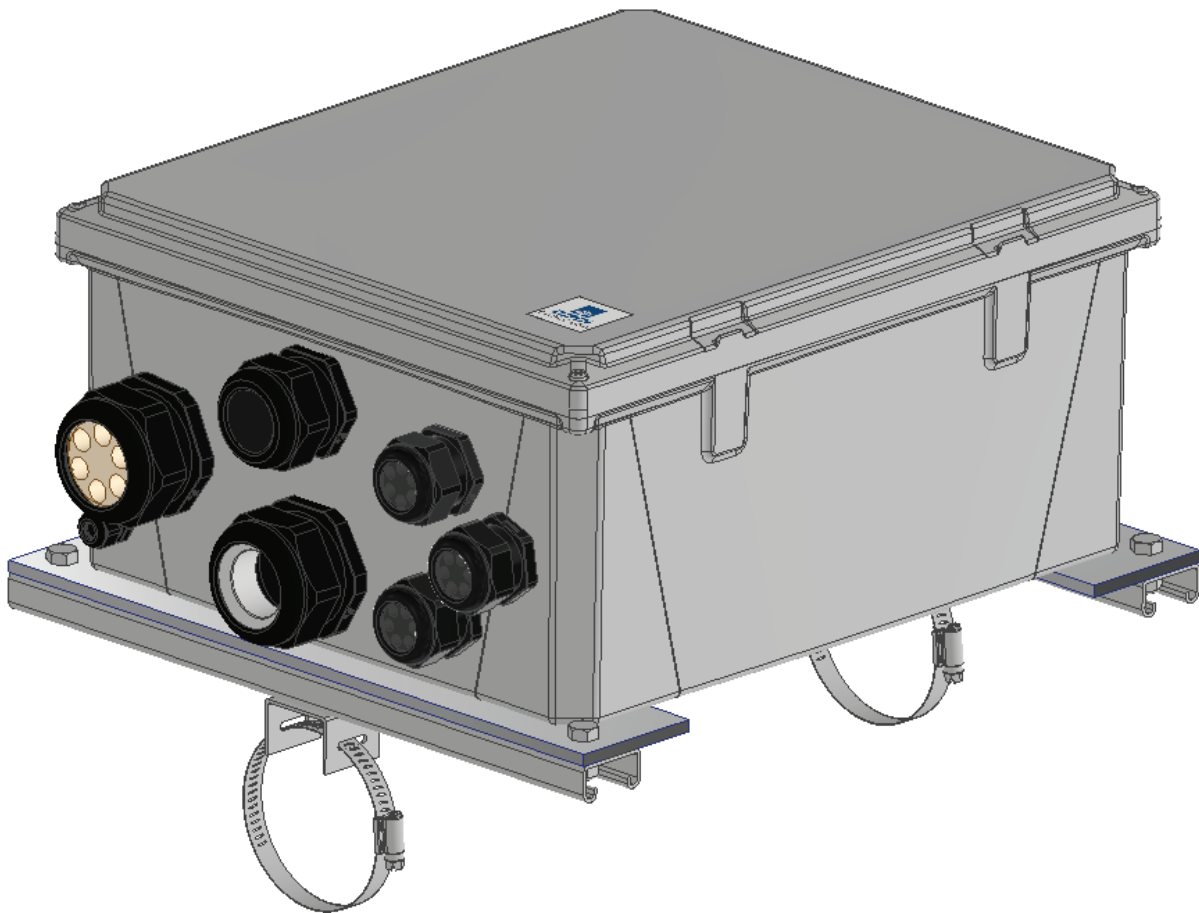

INSTALLATION INSTRUCTIONS

JB007

JUNCTION BOX



PRODUCT FEATURES

- Provides (6) Discrete circuits for (1) 1-1/4" or (1) 7/8" hybrid feeder cable
- Supports up to (6) individual 11 mm DC power jumpers
- Supports up to (18) individual 6.5 mm fiber jumpers
- Junction box can be wall mounted, pole or leg mounted, tower face mounted, monopole mounted

Table of Contents

Disclaimer	2
Warnings	2
Package Contents	3
Required Tools	3
Prerequisites	4
Wall/Surface Mounting Procedure	4
Pole or Leg Mounting	5
Tower Face Mounting	6 - 7
Monopole Mounting	8 - 10
Port Identification	10
Installing Ground Cable	11
Installing Hybrid Cable DC Power (IN)	12
Installing DC Power Jumpers (OUT)	13
Installing Hybrid Cable Fiber (IN)	14
Installing Fiber Jumpers (OUT)	15
Finalizing Installation	16

Disclaimer

The information in this document is subject to change without notice and describes only the product defined in the body of this documentation. This documentation is intended for the use of Eupen Cable USA, Inc. customers only for the purposes of product installation. The documentation has been prepared to be used by professional and properly trained personnel, and the customer assumes full responsibility when using it. Eupen Cable USA, Inc. welcomes any customer comments or feedback. This product is suitable for outdoor use.

Eupen Cable USA, Inc. has made all reasonable efforts to ensure that the instructions contained in this document are adequate and free of material errors and omissions.

The contents of this document are subject to revision without notice. Eupen Cable USA, Inc. shall have no liability for any error damage of any kind resulting from the use of this document.

Warnings

Please read this manual prior to use to become familiar with the product's numerous features and operating procedures. To maintain the maximum degree of safety, follow the sequences as outlined.

Before using this product, read all instructions and caution markings on any equipment connected to this product.

CAUTION – Unless otherwise noted, product usage that is not recommended by the product manufacturer can result in risk of fire, electric shock, or injury to persons.

CAUTION – Do not operate the product if it has been damaged in any way. Return damaged products to manufacturer for repair or replacement.

WARNING – Disconnect or disable the DC power source to the product prior to beginning its installation. Ensure that the DC power source to the product remains de-energized until the completion of the installation and after all connections have been verified to be correctly configured.

ATTENTION – Installation of the hybrid cable requires an approved hanger to be used no more than 3 feet from the entrance of the junction box. Refer to Eupen Cable USA, Inc. installation guidelines for proper hardware use and placement.

CAUTION – Do not bend fiber-optic cables beyond their minimum bend radius. Bending the fibers beyond their minimum bend radius can damage the fibers.

CAUTION – Do not let fiber-optic cables hang free from the connector. All fiber must be secured against movement in wind while maintaining enough slack to prevent any tension along the run. Do not allow fastened loops of cables to dangle, which stresses the cables at the fastening point.

WARNING – Do not look directly into a fiber-optic transceiver or into the ends of fiber-optic cables. Fiber-optic transceivers and fiber-optic cables connected to transceivers emit laser light that can damage your eyes.

For all comments or questions, please contact a Eupen Cable USA, Inc. representative at (800) 419-5100 or www.eupen.us.

Contents



JB007 Junction Box Assembly

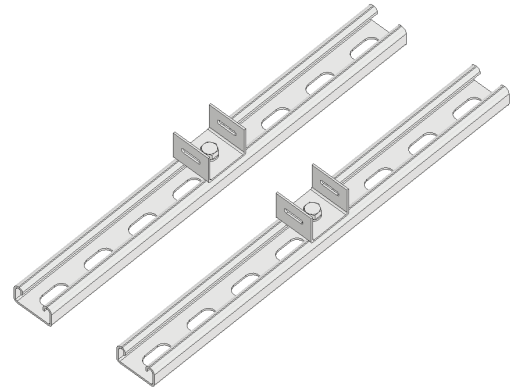

Mounting Bracket Assembly

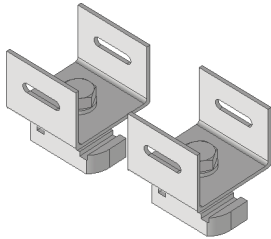

(2) Mounting Brackets

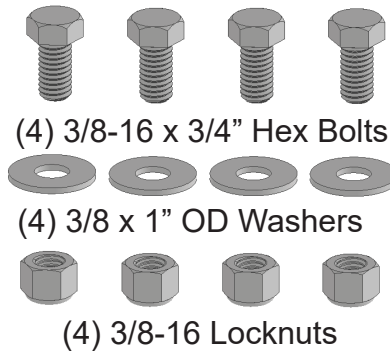

(4) 3/8-16 x 3/4" Hex Bolts

(4) 3/8 x 1" OD Washers

(4) 3/8-16 Locknuts



(2) 2" - 4" (51-102mm) Dia
Pipe Clamps

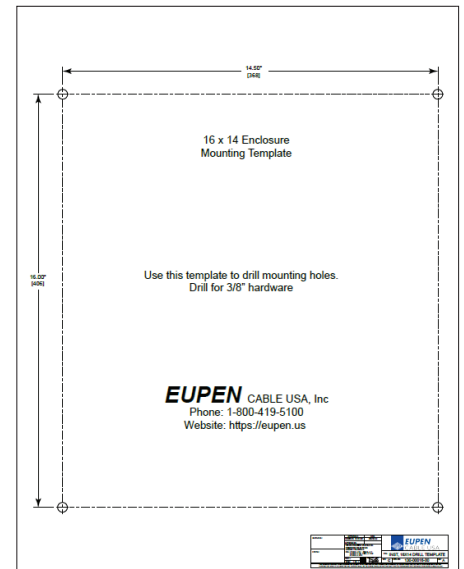

Wall Mount Drill Template

Required Tools

- Wire Cutters
- Wire Strippers
- Flat Head Screwdriver
- Cross Head Screwdriver
- Needle Nose Pliers
- 9/16" or Adjustable Wrench
- 9/16" Hex Socket
- Rip Cord Tool Kit (KT114 or KT78)
- Banding Crimp Tool (Optional)

Prerequisites

This document describes how to install the JB007 junction box on-site and how to mount, and connect it to external interfaces.

Installers of junction box must be industry professionals who have attended training on the proper installation of the equipment by Eupen Cable USA, Inc. and/or the mobile operator. Installers are required to read this installation guide thoroughly prior to installation of the product.

Installers shall obey all general and regional installation and safety regulations related to work on high voltage installations, as well as regulations covering correct use of tools and personal protective equipment. Use this equipment only for the purpose specified by the manufacturer. Do not make any modifications or fit any parts that are not recommended by the manufacturer. This could result in electric shock or other injuries.

Wall/Surface Mounting Procedure

Junction box ships from factory set up for Wall/Surface mounting.

- Using supplied drill template, tape template to wall or mounting surface and mark each mounting hole location, making sure there is sufficient clearance on sides and bottom of unit for cover to open and cable installation.
- Mount is designed for 3/8" mounting hardware. Drill (4) mounting holes dependant on installers method of attaching mounting plates to wall.
- Secure junction box to the wall or mounting surface with cable glands facing down.
(Mounting hardware not supplied)

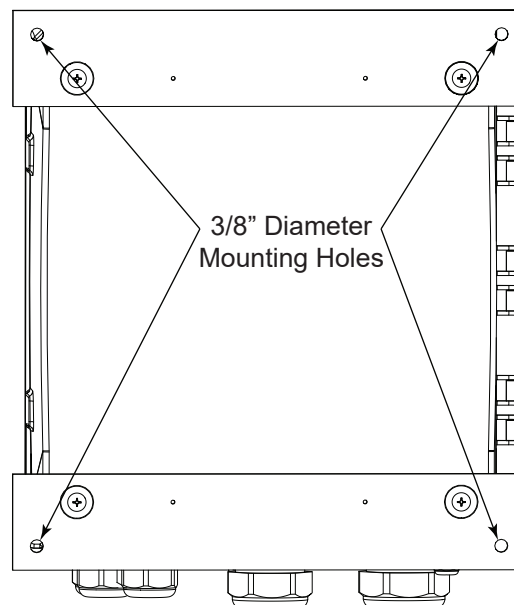
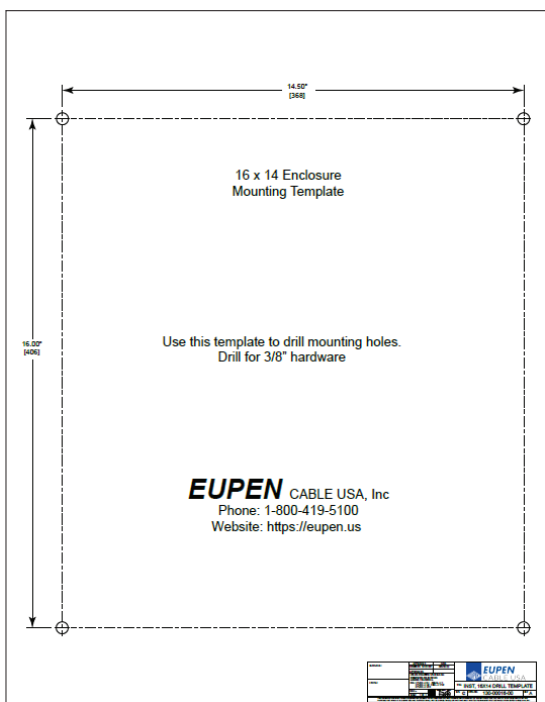

Pole or Leg Mounting

- Attach Mounting Bracket Assembly to top and bottom junction box mounting plates using (4) supplied 3/8-16 Hex Bolts, Flat Washers and Locknuts. **(Figure A)**

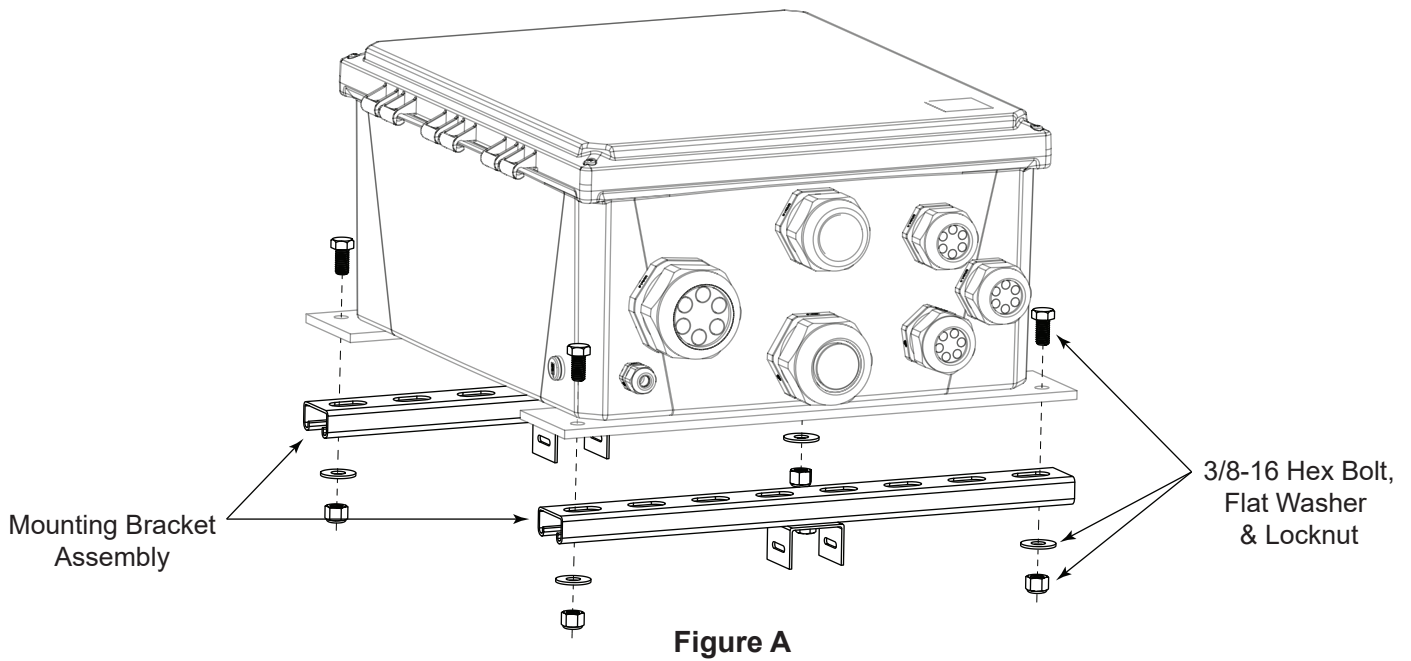

- Install Pipe Clamps through both slots of mounting bracket on each Mounting Bracket Assembly. **(Figure B)**

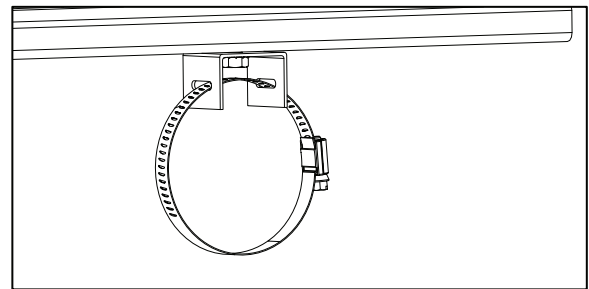

- Secure assembly to vertical pole or tower leg. **(Figure C)**

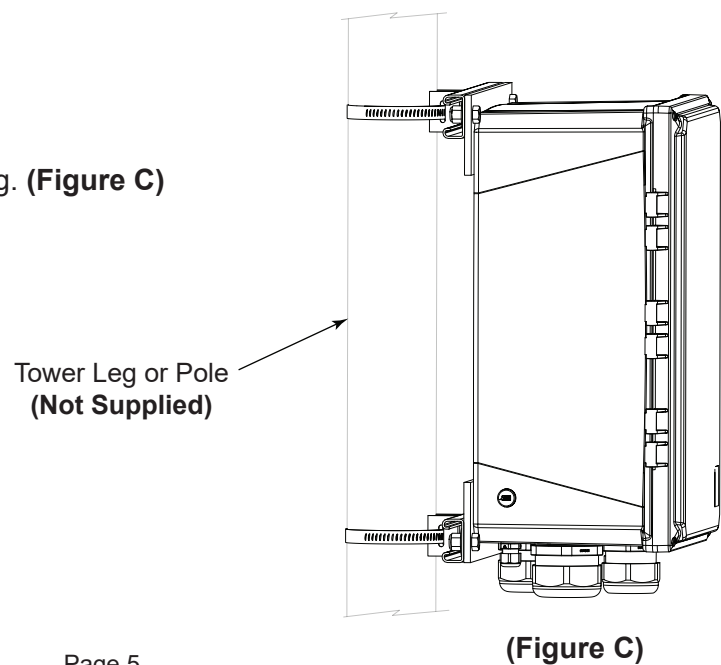

Tower Face Mounting

JB007 is designed to allow the assembly to be mounted to either a tower face cross member using supplied Mounting Bracket Assembly, or across a large tower face using supplied Mounting Brackets and longer length unistrut channel (**Not Supplied**)

Horizontal Tower Cross Member:

- Attach Mounting Bracket Assembly to top junction box mounting plate using (2) supplied 3/8-16 Hex Bolts, Flat Washers and Locknuts. (**Figure D**)

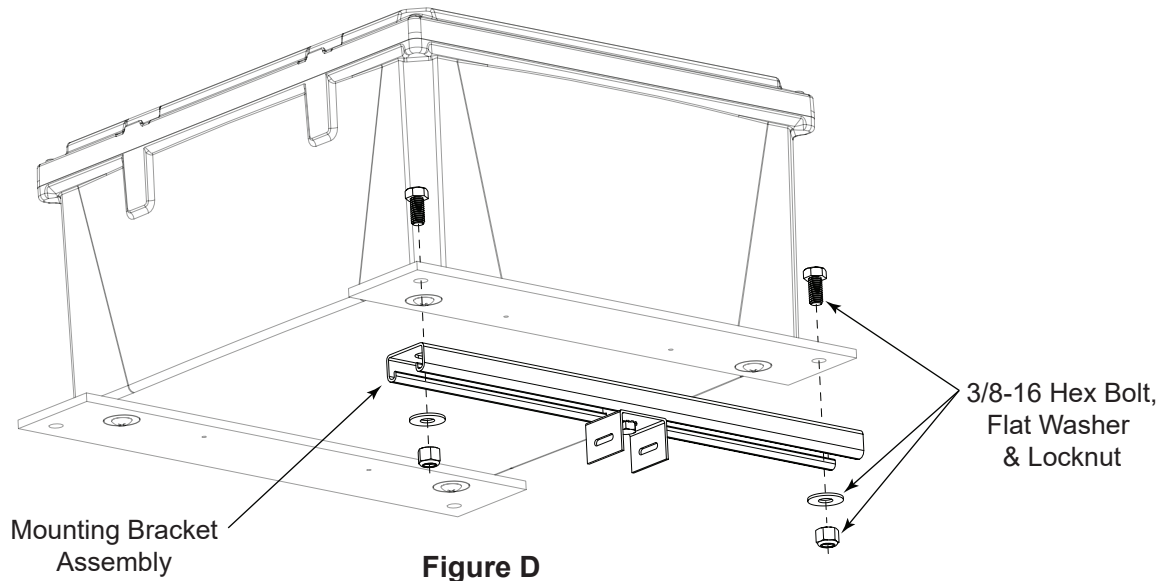

- Loosen attached Mounting Bracket and slide bracket to left until it reaches the 3/8 hex bolt. (**Figure E**)

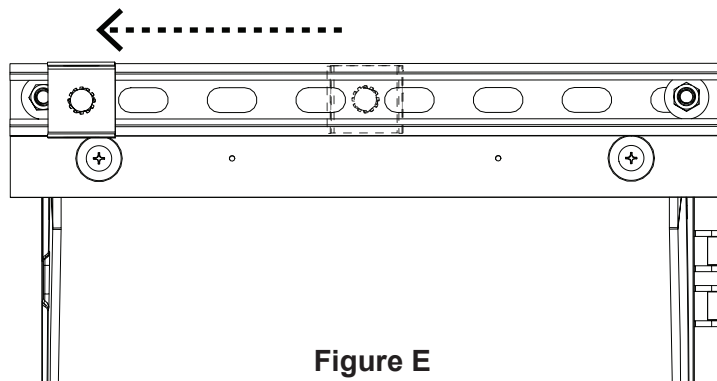

- Take supplied Mounting Bracket and insert into unistrut channel and slide to the right until it reaches 3/8 hex bolt. Rotate the channel nut 90° to the right to lock channel nut into channel but don't tighten. (**Figure F**)

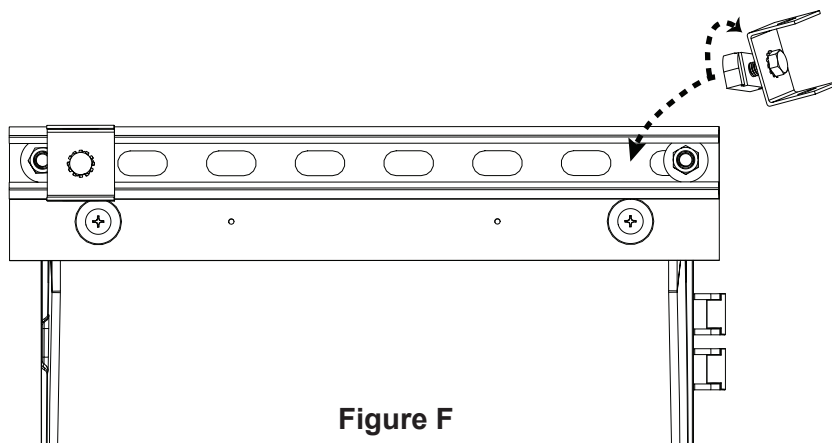

NOTE: When installing channel nut, ensure nut is fully rotated to the right and grooves in nut are hooked into channels before tightening.

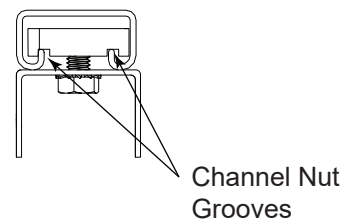

Figure F

Tower Face Mounting (Continued)

- Rotate both Mounting Brackets to tighten into place. Continue rotating Mounting Brackets to orient as shown. (Figure G)

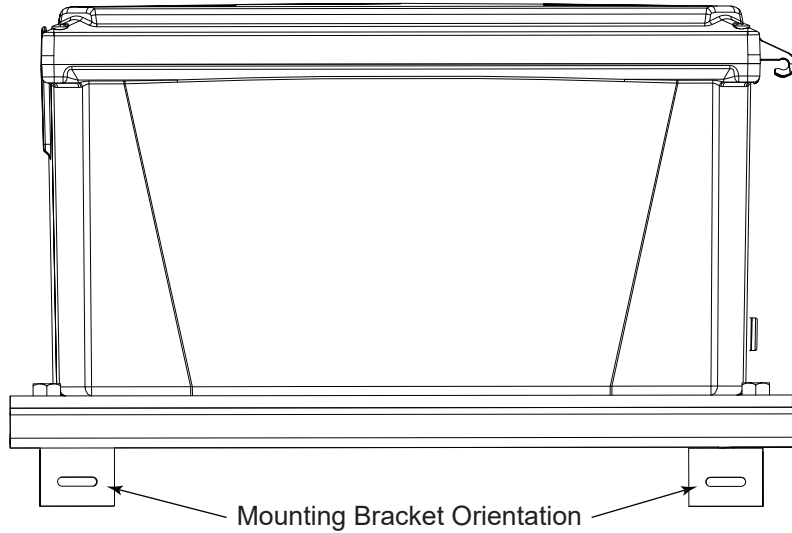

Figure G

- Secure assembly to horizontal cross member. (Figure H).

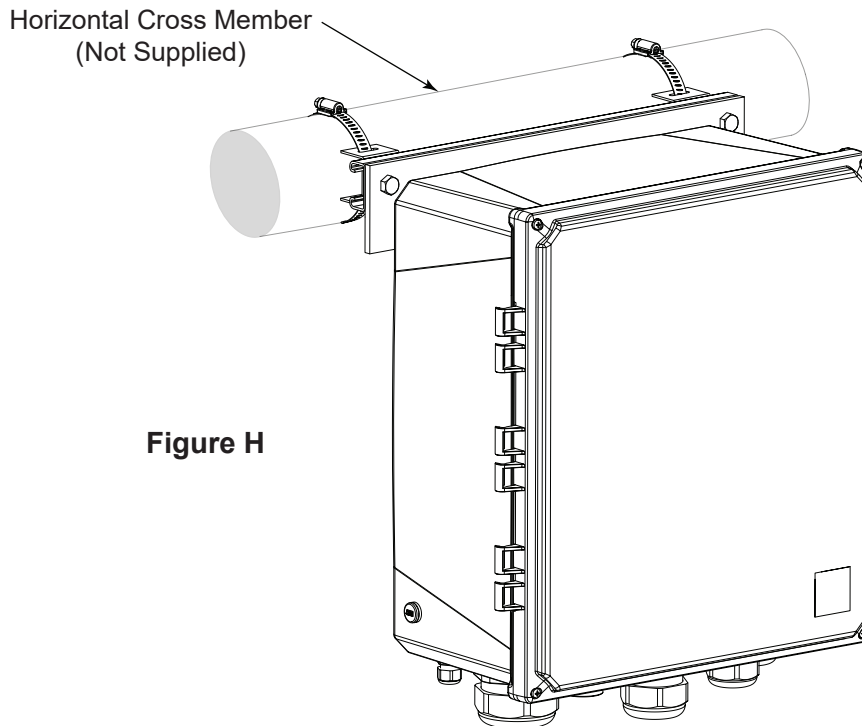
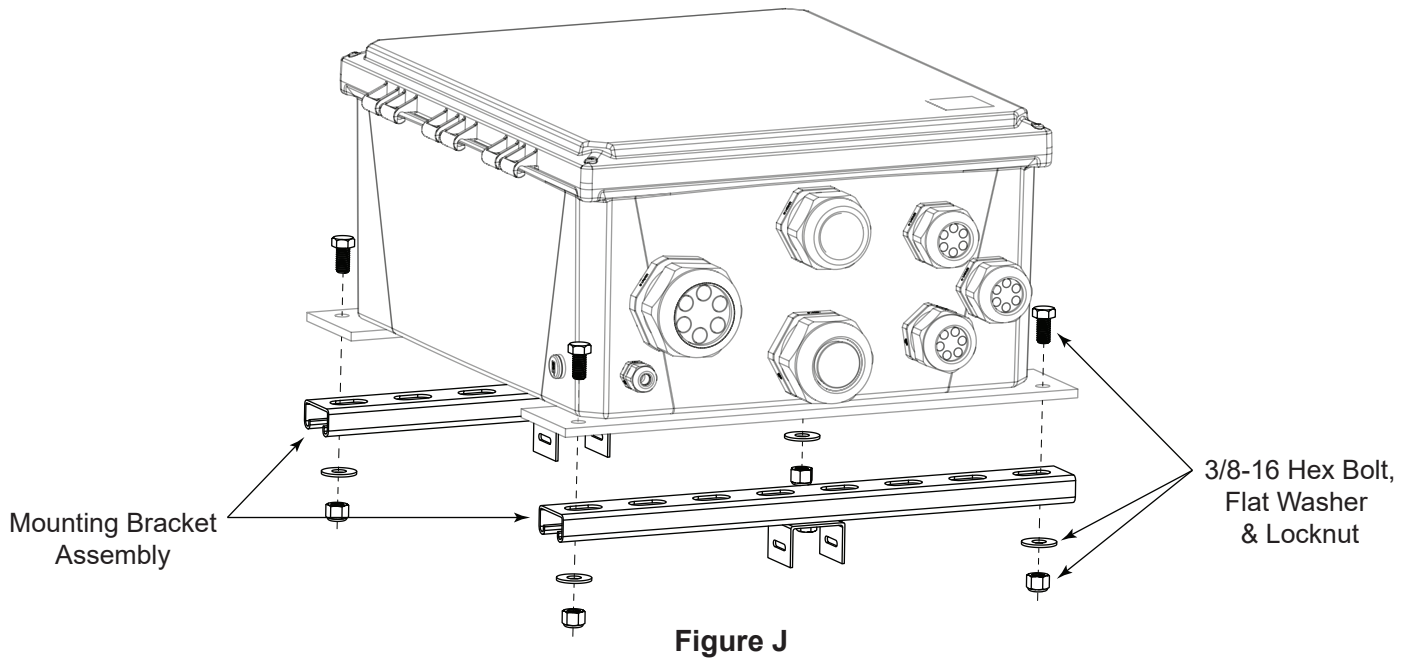

Figure H

NOTE: To attach junction box to a tower face using supplied Mounting Brackets, replace both supplied 16" long 1-5/8" slotted unistrut channels with longer lengths of unistrut channel (**not supplied**) that will fit across tower face. Attach longer length 1-5/8" unistrut channels to junction box as noted in **Figure A** and install Mounting Brackets into channels at required spacing. Rotate Mounting Brackets to tighten into place. JB007 is supplied with two pipe clamps. Two additional pipe clamps (**not supplied**) will be required for this method of installation.

Monopole Mounting

- Attach Mounting Bracket Assembly to top and bottom junction box mounting plates using (4) supplied 3/8-16 hex bolts, flat washers and locknuts. **(Figure J)**



- Loosen attached Mounting Bracket and slide bracket to left to line up bracket bolt center with Locator Holes in mounting plate. Repeat process for bottom Mounting Bracket. **(Figure K)**

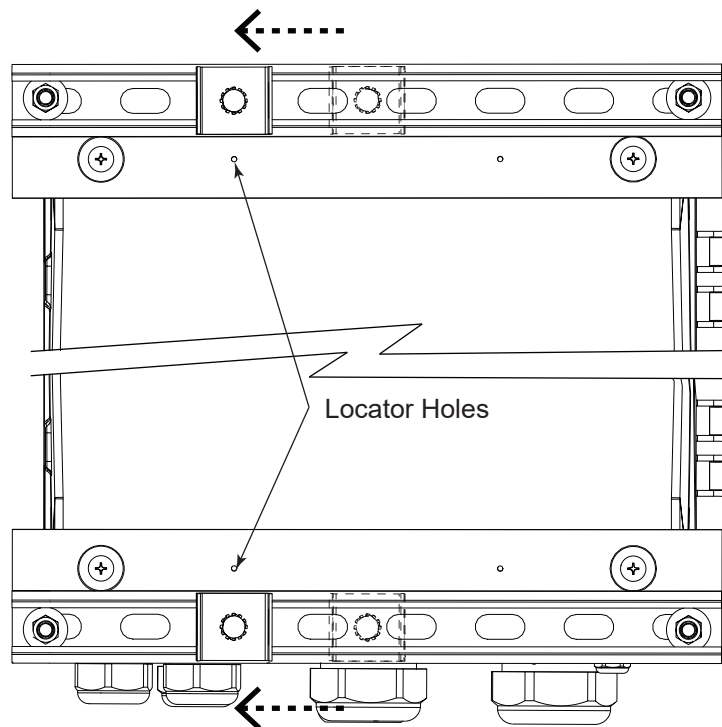

Monopole Mounting (Continued)

- Take supplied Mounting Bracket and insert into unistrut channel. Rotate the channel nut 90° to the right to lock channel nut into channel but don't tighten. Repeat process for bottom Mounting Bracket (**Figure L**)

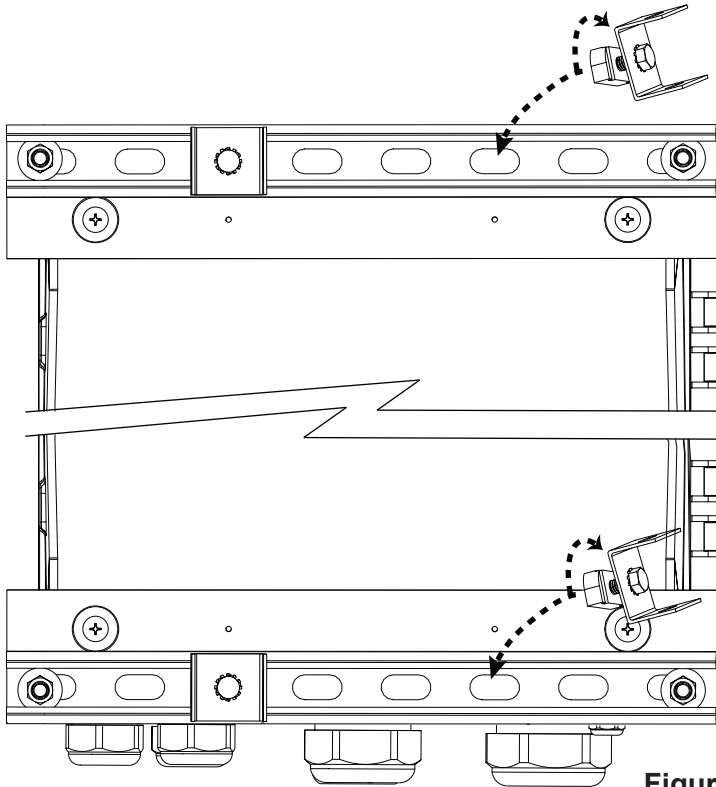

NOTE: When installing channel nuts, ensure nut is fully rotated to the right and grooves in nuts are hooked into channels before tightening.

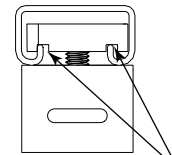

Channel Nut Grooves

Figure L

- Align added Mounting Bracket bolt center with right Locator Holes. Rotate both brackets to tighten into place. Continue rotating Mounting Brackets to orient as shown. Repeat process for lower Mounting Bracket. (**Figure M**).

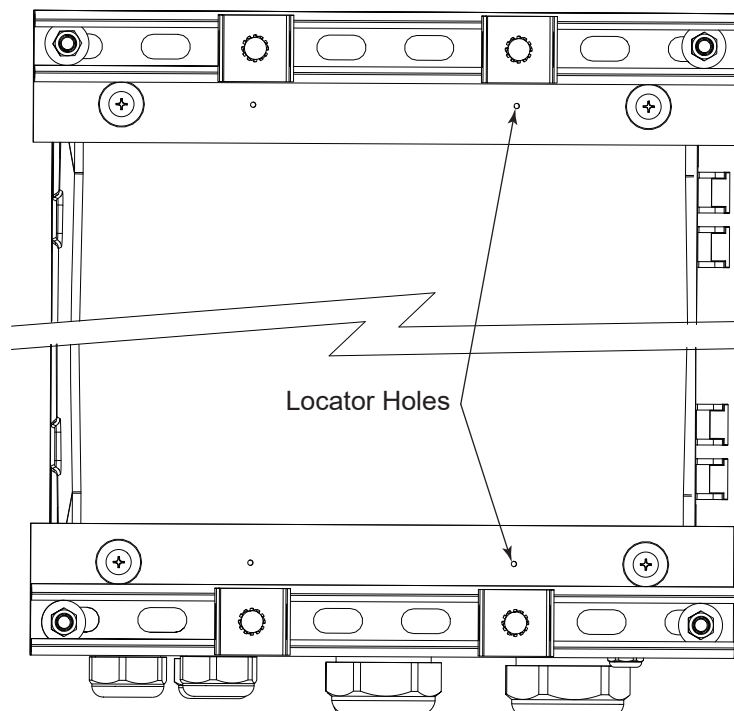

Figure M

Monopole Mounting (Continued)

- To mount junction box to a monopole, route mount banding (not supplied) through the inner slot of each upper Mounting Bracket. Slots will accept banding widths up to 3/4" wide. Repeat process for bottom Mounting Bracket. **(Figure N)**

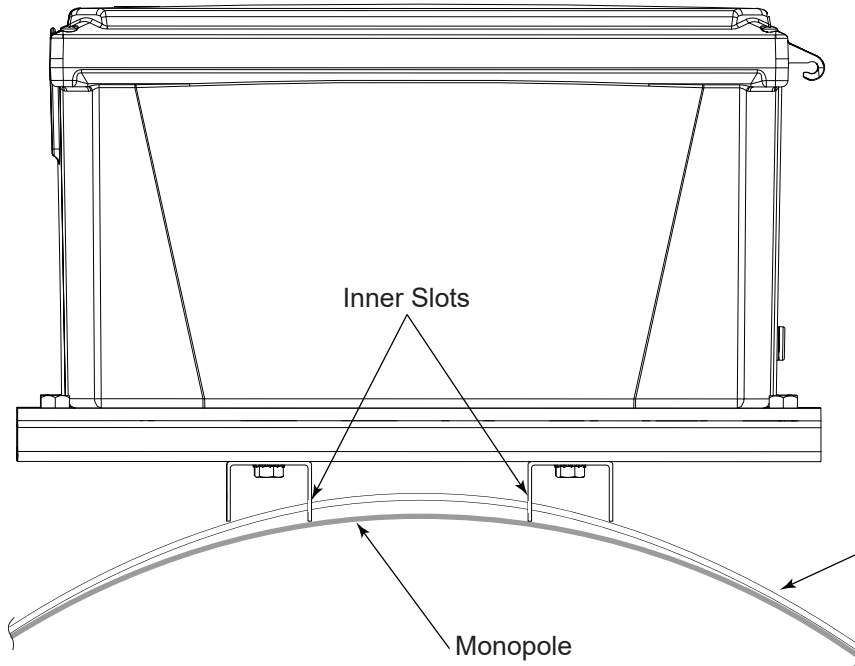

Figure N

Banding (not supplied)
1/2" wide Banding, Clips, & Tool
available for purchase from
Eupen Cable USA, Inc.
Banding P/N: MT-640 (100' roll)
Clip P/N: MT-641 (100 pk)
Tool P/N: MT-644
For more information please contact
Eupen Cable USA Customer Service
1 (800) 419-5100

Port Identification

- See **Figure P** to identify junction box port locations.

NOTE: Ports are positioned on bottom of junction box, and must always be mounted facing down.

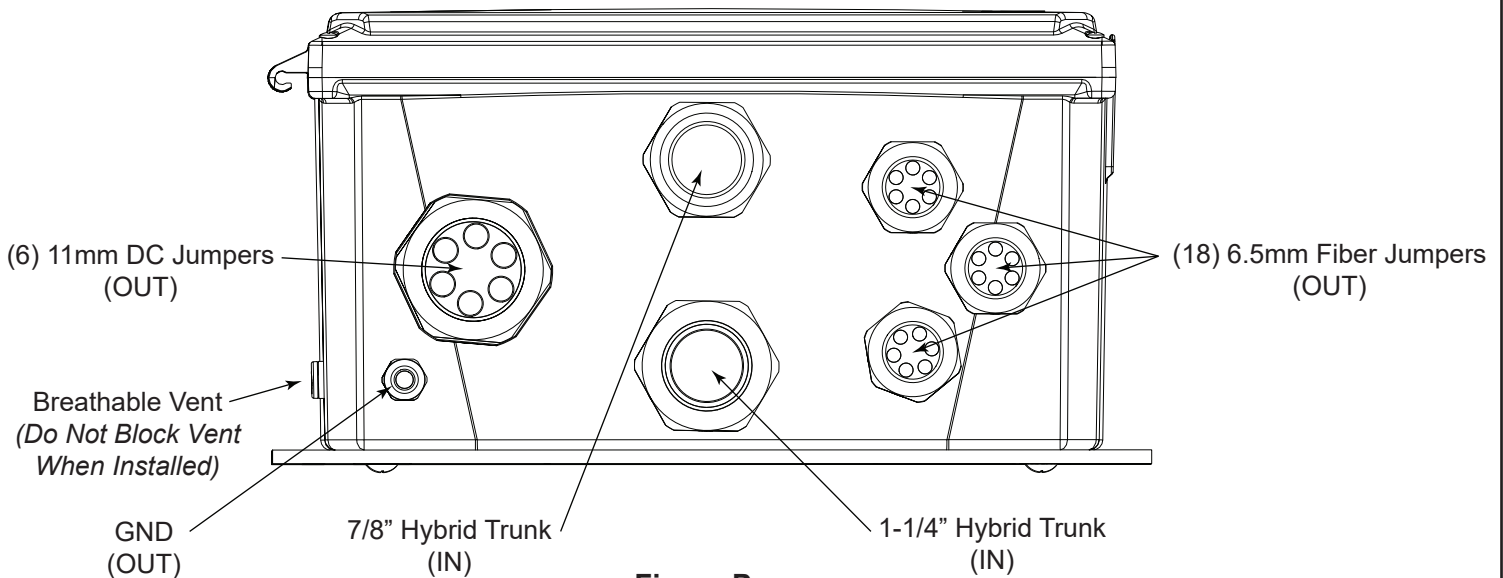
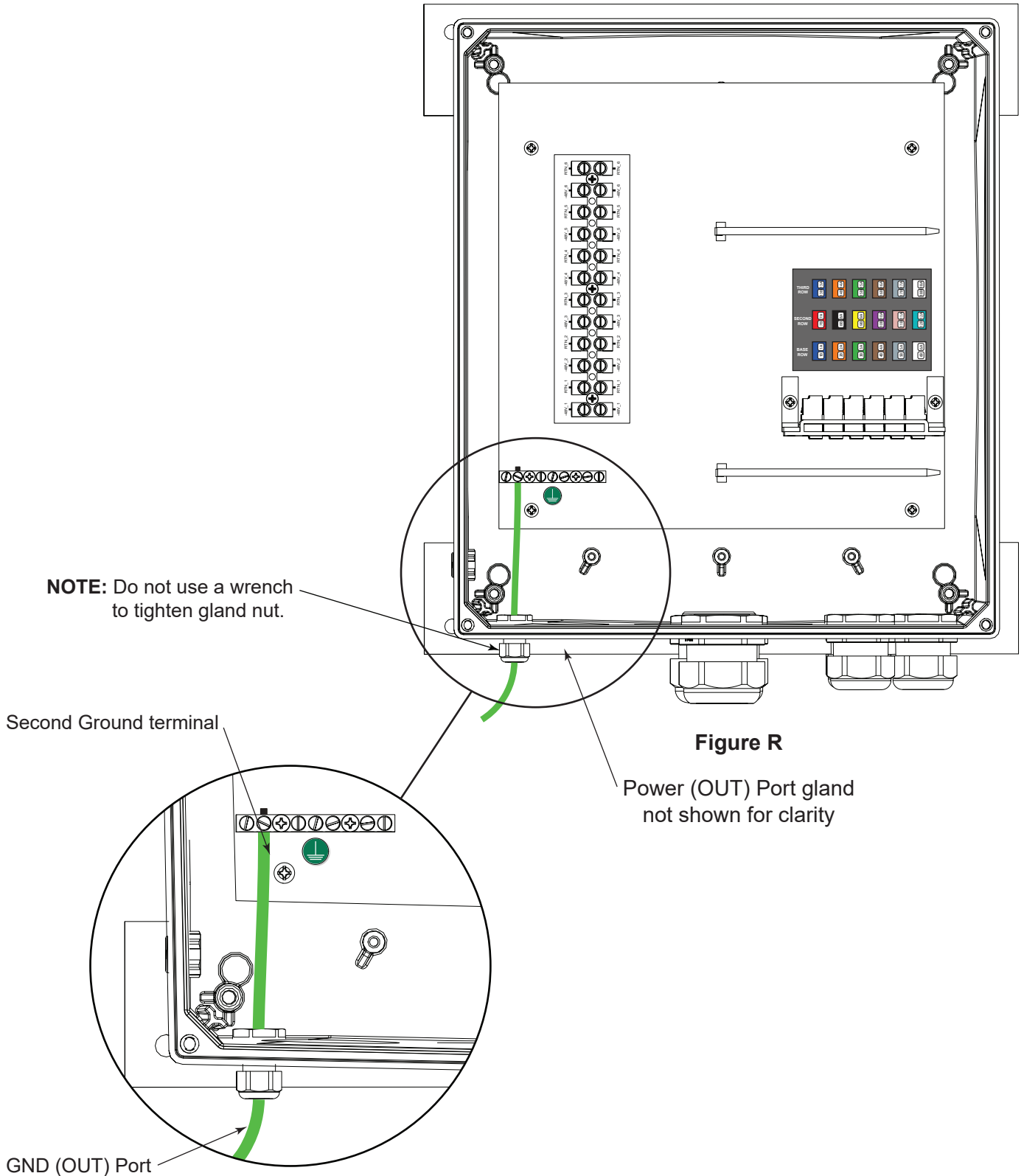

Figure P

Installing Ground Cable

- Remove port gland nut and slide onto cable before inserting through port gland.
- Feed main ground wire through GND (OUT) port. Strip jacket and secure to second terminal of ground bar. **(Figure R)**
- Once ground wire is secured, thread gland nut back onto port gland hand tight.



Installing Hybrid Cable DC Power (IN)

- Remove appropriate port gland nut and slide onto cable before inserting through port gland.
- Feed hybrid cable through either the 7/8" or 1-1/4" Hybrid Trunk (IN) port starting with fibers. **(Figure S)**
- Route all fiber sub-units and power wires up the center of junction box, taking care not to overbend or damage any fibers in the hybrid cable breakout. **(Figure S)**
- Cut and strip jacket for each power cable.
- Starting from the bottom terminal (Circuit 1), connect each power cable according to your established color code. **(Figure S)**
- Repeat for each circuit.
- Once power wires are secured, thread gland nut back onto port gland **hand tight**.

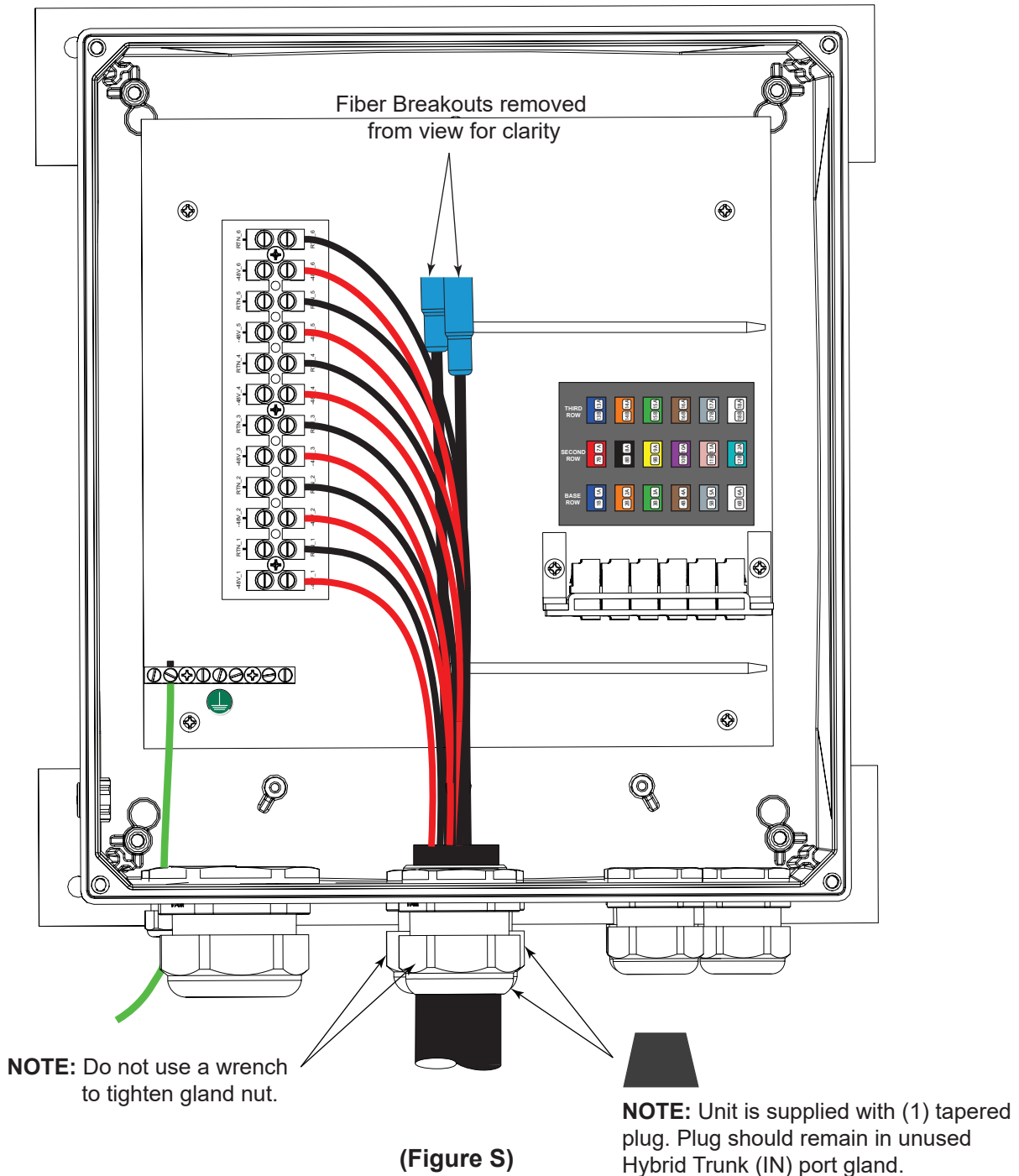

Installing DC Power Jumpers (OUT)

- Remove port gland nut and slide over all power jumpers before inserting into gland insert and port gland.
- Remove gland insert and insert power jumpers through each of (6) insert holes. **(Figure T)**
- After inserting power jumpers into each hole in the gland insert, reinstall gland insert back into gland.
- Loosely screw gland nut back onto port gland to hold power jumpers in place (do not tighten).
- Strip enough jacket to expose and feed jumper cable braid into next available terminal position on ground bar (left to right). **(Figure T)**
- Cut and strip wire jacket for each power jumper cable.
- Starting from the bottom terminal (Circuit 1), connect each power jumper cable according to your established color code. **(Figure T)**
- Repeat for each circuit.
- Once power wires are secured, tighten gland nut **hand tight**.

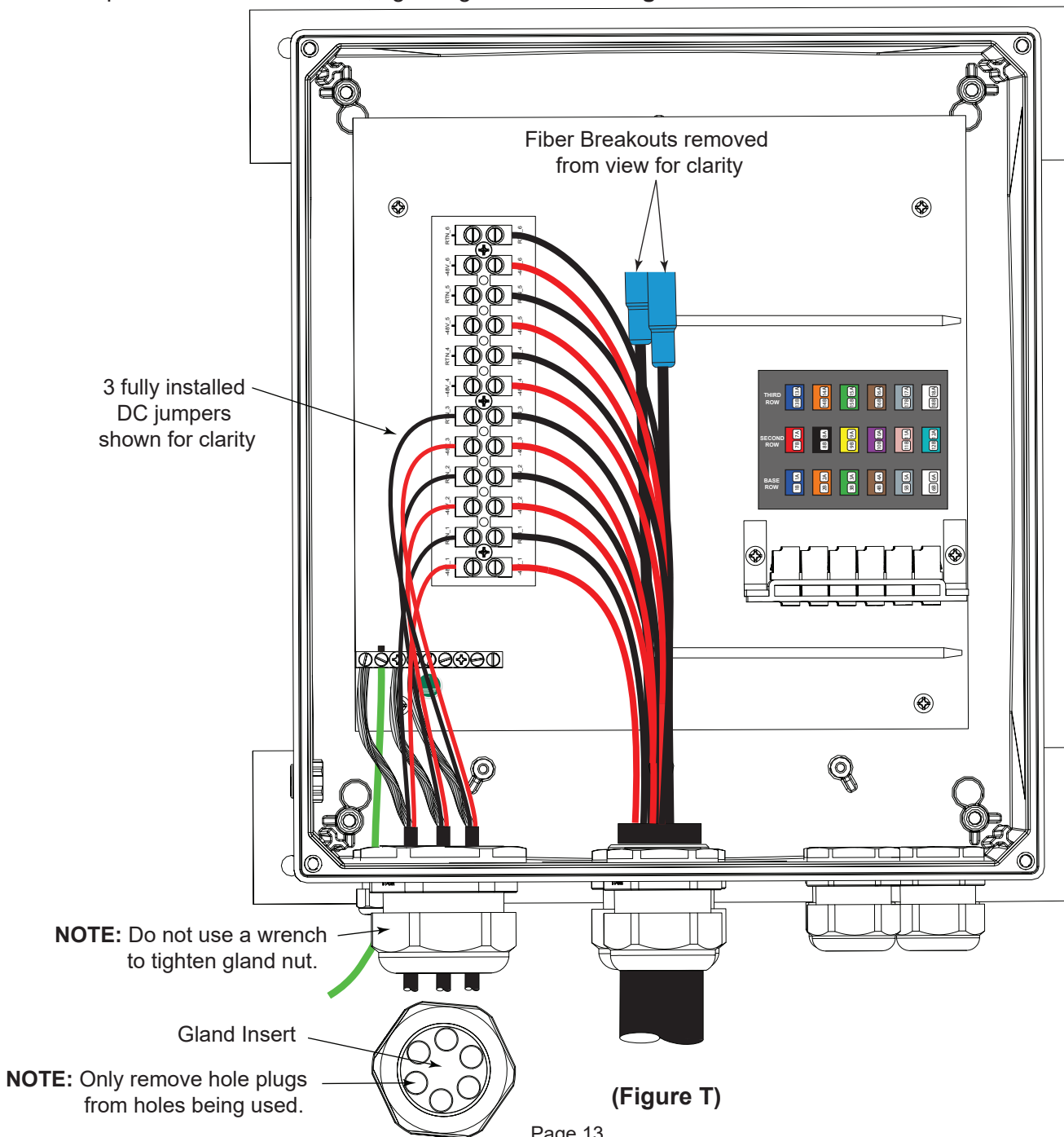

Installing Hybrid Cable Fiber (IN)

- Loosely loop all fibers around the top corner of the junction box as shown, Connect each fiber into fiber panel starting with the bottom (Base) row, left side and working to the right, then start on second (Top) row. Fiber position and fiber color label provided for reference (**Figure U**)
- Remove the dust caps on the fiber connectors to be used. To avoid contamination, do not remove any dust caps until fiber is immediately ready to install.

(Example: Remove dust caps on fiber pair, clean and inspect as needed, plug fiber pair into adapter panel, repeat)

- After all fibers are connected, use Panel Mounted Cable Ties to secure power cables and fiber sub-units into place. Bottom Cable Tie should be used around all fiber sub-units and power cables.

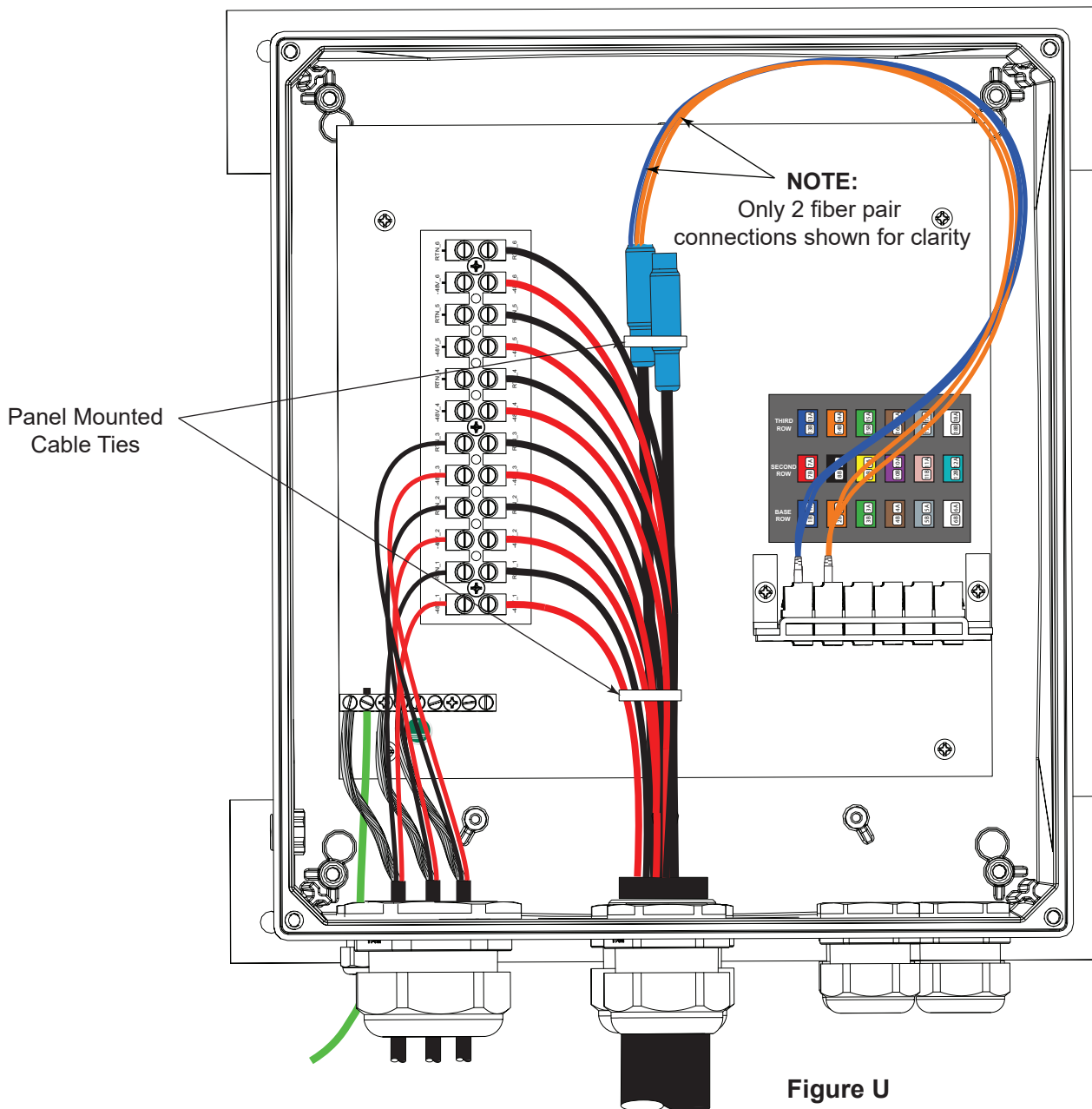

Installing Fiber Jumpers (OUT)

- Remove each port gland nut and slide over (6) fiber jumpers before inserting into gland insert and port gland.
- Remove gland insert and insert fiber jumpers through each of (6) insert holes in either top or bottom Fiber Jumper (OUT) Trunk port. **(Figure V)**
- Push all fiber jumpers through the port gland and reinsert 6 hole gland insert back into each port gland.
- Loosely screw gland nut back onto each port gland to hold fiber jumpers in place.
- Remove the dust caps on the fiber connectors to be used. To avoid contamination, do not remove any dust caps until fiber is immediately ready to install into panel.

(Example: Remove dust caps on fiber pair, clean and inspect as needed, plug fiber pair into adapter panel, repeat)

- Once fiber jumpers are connected, carefully pull slack out of each fiber jumper before hand tightening gland nuts.

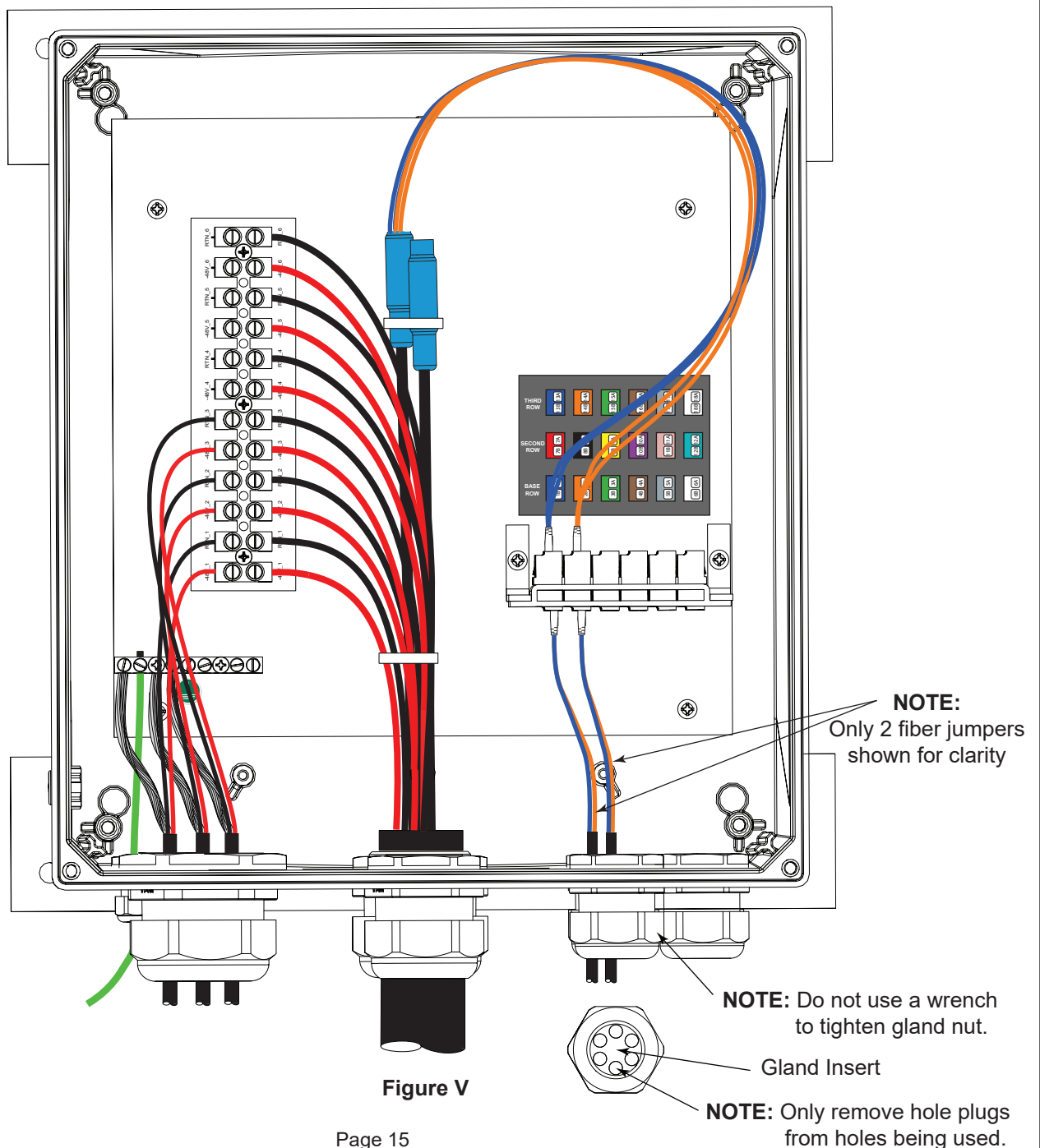
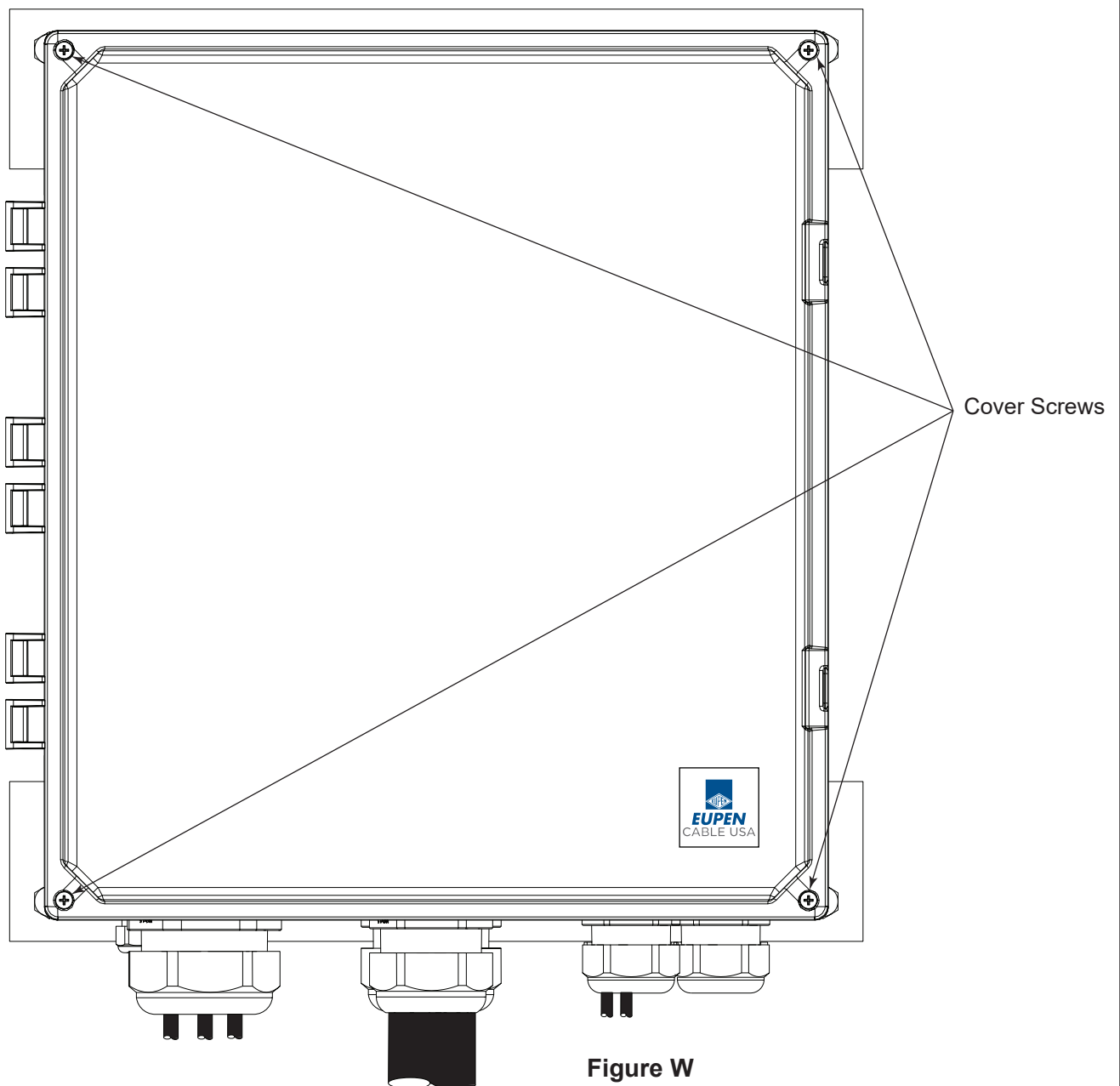

Figure V

Finalizing Installation

- To finalize installation, ensure all ground and power terminal screws are securely tightened to prevent wires from coming loose. Ensure all port gland nuts are hand tightened to secure cables and wires from slipping out.
- Junction Box cover is supplied with factory installed captivation washers to prevent cover screws from falling out.
- Swing cover closed and tighten (4) Cover Screws. **(Figure W)**

NOTE: Before closing cover, ensure all wires and fibers are secured and safely positioned inside of junction box to prevent wires or fibers from interfering with cover flange and gasket.





EUPEN CABLE USA

Cable experience you can trust

CLEARWATER, FL | ARLINGTON, TX

TOLL FREE: 800.419.5100 | FAX: 727.528.0751 | WWW.EUPEN.US